

# Powering an Air Conditioner from 12v DC sources

## Overview

There are an increasing number of requests for small marine air conditioning systems that can be run from a 12v DC source. These are for use either when the engine is running, with the alternator being

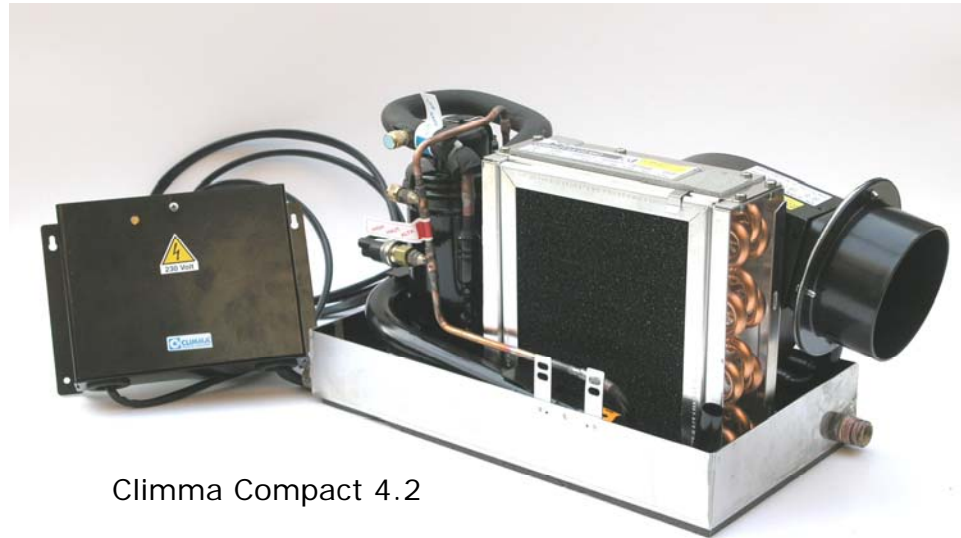

Climma Compact 4.2

the power source, but also from a battery bank for sleeping overnight. If the system is to be used primarily at the end of the day for sleeping, then cooling and dehumidifying the area initially while the engine is running will greatly reduce the overnight power consumption. If the vessel is a small powerboat, the system can be operated whenever the engine is running, and if the air discharge

is shared between the sleeping area and a "Helm Cooler" nozzle installed in or near the dash, this can provide a refreshing blast of cold air for the operator in summer, or be a demister if in heat mode.

## Power Considerations

A Climma Compact 4.2 will draw, on average, between 35 and 40 amps at 12v DC, including the water pump and inverter loss. Compressor starting loads are not significant, and a 700 watt inverter gives ample power to start and run the system, with power to spare. When using the system overnight for sleeping, it must be considered that once the sun goes down the heat load diminishes greatly, and as the night draws on, the cooling requirements are greatly reduced. As a guide, an air conditioning system operated overnight can be expected to run just 25% to 30% of the time, so over an average night, the power consumption of a Climma Compact 4.2 can normally be less than 100 amp/hrs.

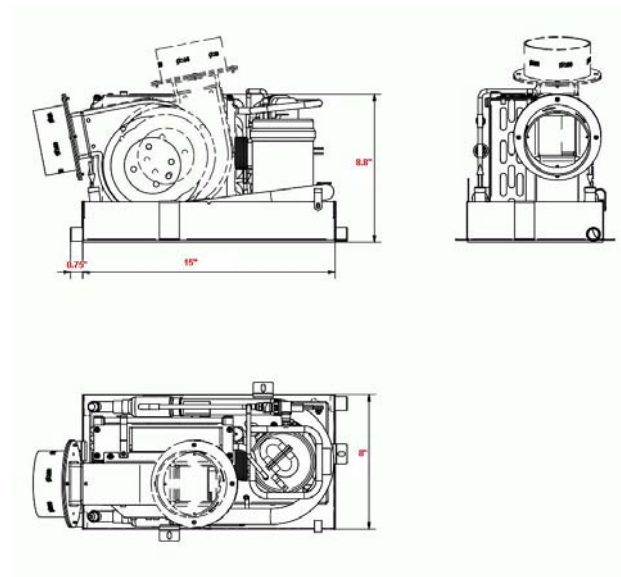

## Options

There are two choices when planning an air conditioning system intended to be operated from a 12v DC source. Either install a dedicated 12v DC system, or a 110v AC system running through an inverter. Below are some of the reasons why a 110v AC system with inverter is the logical choice.

## Components

Components for 115v AC powered air conditioners are manufactured in their millions, and there is a wide choice of parts available. Climma selects compatible components that are suitable for the marine mobile environment for the Compact 4.2, and the parts are extremely reliable and widely available. In contrast, there is a very limited choice of components to use for a 12v DC air conditioner, and so compromises have to be made when manufacturing such a system, and the costs are significantly higher. Unlike dedicated 12v DC units, the Climma Compact 4.2 is available as cool-only or with reverse-cycle heat.

## Installation

One major drawback of a 12v DC system is that it will require a significantly lengthy run of large battery cables to power it, and this is both expensive and increases the power consumption. A Climma 110v AC system can be powered from either a “whole-boat” inverter, or a small dedicated model, either of which would be mounted very close to the battery, enabling much smaller wiring to be run to the air conditioner. A “Pure Sine Wave” inverter should be installed and not a “modified” or “quasi” sine wave model.

## Controls

A marine 12v DC air conditioning will have a basic and rudimentary control, whereas a Climma 110v AC model will share a control used by other systems in the Climma range, even by big yachts with chiller systems. This is a dedicated marine control that will give all the benefits of precise temperature control, humidity control, electronic fan speed control, etc.



Climma Vega MK III Control

## Efficiency

Even though there is a small energy loss when using an inverter to power a 110v Climma system from 12v DC, this is more than compensated for by the much higher efficiency of a Climma model compared to a purely 12v DC unit. Thanks to the quality of the engineering and design, and by using the best components, Climma air conditioning systems are well known for their high energy efficiency, superior cooling capability, and low noise levels.

Small Climma Compact 110v AC models are usually configured to work with a dedicated 12v DC pump via a small Power Converter. The quiet and reliable 12v pump specified for use with the Compact 4.2 draws less than one amp at 12v, can be mounted above the waterline, and can share a raw water intake.

## Size/Capacity

Unlike residential and commercial air conditioning, marine manufacturers are not regulated and can label their products to show whatever Btu capacity they choose. Climma products are rated according to stringent tests at controlled conditions, and have proved to outperform other manufacturers’ units of the same labeled capacity.



PO Box 4535, Annapolis, MD 21403  
301.352.5738 voice info@CoastalClimateControl.com